

Centre Scientifique et Technique du Bâtiment

84 avenue Jean Jaurès
CHAMPS-SUR-MARNE
F-77447 Marne-la-Vallée Cedex 2
Tél. : (33) 01 64 68 82 82
Fax : (33) 01 60 05 70 37

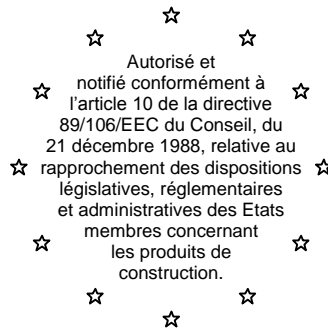

MEMBRE DE L'EOTA

European Technical Approval

ETA-01/0009

(English language translation, the original version is in French language)

Nom commercial :

Trade name:

FM 753 A4

Titulaire :

Holder of approval:

Société FRIULSIDER SpA

33048 San Giovanni al Natisone

Via Trieste, 1 (Udine)

ITALY

Type générique et utilisation prévue du produit de construction :

Cheville métallique en acier inoxydable, à expansion par vissage à couple contrôlé, de fixation dans le béton non fissuré : diamètres M8, M10, M12 et M16.

Generic type and use of construction product:

Torque-controlled expansion anchor, made of stainless steel, for use in non cracked concrete: size M8, M10, M12 and M16.

Validité du :
au :

18/10/2011

18/10/2016

Validity from / to:

Usine de fabrication :

Manufacturing plant:

Société FRIULSIDER SpA

33048 San Giovanni al Natisone

Via Trieste, 1 (Udine)

ITALY

Le présent Agrément technique européen contient :

This European Technical Approval contains:

12 pages incluant 5 annexes faisant partie intégrante du document.

12 pages including 5 annexes which form an integral part of the document.

This European Technical Approval replaces ETA-01/0009 with validity from 18/10/2006 to 18/10/2011

Cet Agrément Technique Européen remplace l'Agrément ETA-01/0009 valable du 18/10/2006 au 18/10/2011



Organisation pour l'Agrément Technique Européen
European Organisation for Technical Approvals

I LEGAL BASES AND GENERAL CONDITIONS

1. This European Technical Approval is issued by the Centre Scientifique et Technique du Bâtiment in accordance with:
 - Council Directive 89/106/EEC of 21 December 1988 on the approximation of laws, regulations and administrative provisions of Member States relating to construction products¹, modified by the Council Directive 93/68/EEC of 22 July 1993²;
 - Décret n° 92-647 du 8 juillet 1992³ concernant l'aptitude à l'usage des produits de construction;
 - Common Procedural Rules for Requesting, Preparing and the Granting of European Technical Approvals set out in the Annex of Commission Decision 94/23/EC⁴;
 - Guideline for European Technical Approval of « Metal Anchors for use in Concrete » ETAG 001, edition 1997, Part 1 « Anchors in general » and Part 2 « Torque-controlled expansion anchors ».
2. The Centre Scientifique et Technique du Bâtiment is authorised to check whether the provisions of this European Technical Approval are met. Checking may take place in the manufacturing plant (for example concerning the fulfilment of assumptions made in this European Technical Approval with regard to manufacturing). Nevertheless, the responsibility for the conformity of the products with the European Technical Approval and for their fitness for the intended use remains with the holder of the European Technical Approval.
3. This European Technical Approval is not to be transferred to manufacturers or agents of manufacturer other than those indicated on page 1; or manufacturing plants other than those indicated on page 1 of this European Technical Approval.
4. This European Technical Approval may be withdrawn by the Centre Scientifique et Technique du Bâtiment pursuant to Article 5 (1) of the Council Directive 89/106/EEC.
5. Reproduction of this European Technical Approval including transmission by electronic means shall be in full. However, partial reproduction can be made with the written consent of the Centre Scientifique et Technique du Bâtiment. In this case partial reproduction has to be designated as such. Texts and drawings of advertising brochures shall not contradict or misuse the European Technical Approval.
6. The European Technical Approval is issued by the approval body in its official language. This version corresponds to the version circulated within EOTA. Translations into other languages have to be designated as such.

¹ Official Journal of the European Communities n° L 40, 11.2.1989, p. 12

² Official Journal of the European Communities n° L 220, 30.8.1993, p. 1

³ Journal officiel de la République française du 14 juillet 1992

⁴ Official Journal of the European Communities n° L 17, 20.1.1994, p. 34

II SPECIFIC CONDITIONS OF THE EUROPEAN TECHNICAL APPROVAL

1 Definition of product and intended use

1.1. Definition of product

The FM 753 A4 anchor is an anchor made of stainless steel of sizes M8, M10, M12 and M16, which is placed into a drilled hole and anchored by torque-controlled expansion. For the installed anchor see Figure given in Annex 1.

1.2. Intended use

The anchor is intended to be used for anchorages for which requirements for mechanical resistance and stability and safety in use in the sense of the Essential Requirements 1 and 4 of Council Directive 89/106/EEC shall be fulfilled and failure of anchorages made with these products would compromise the stability of the works, cause risk to human life and/or lead to considerable economic consequences. The anchor is to be used only for anchorages subject to static or quasi-static loading in reinforced or unreinforced normal weight concrete of strength classe C 20/25 at minimum and C 50/60 at most according to EN 206-1: 2000-12. It may be anchored in non-cracked concrete only.

The anchor may be used in concrete subject to dry internal conditions and also in concrete subject to external atmospheric exposure (including industrial and marine environment), or exposure in permanently damp internal conditions, if no particular aggressive conditions exist. Such particular aggressive conditions are e.g. permanent, alternating immersion in seawater or the splash zone of seawater, chloride atmosphere of indoor swimming pools or atmosphere with extreme chemical pollution (e.g. in desulphurization plants or road tunnels where de-icing materials are used).

The provisions made in this European Technical Approval are based on an assumed intended working life of the anchor of 50 years. The indications given on the working life cannot be interpreted as a guarantee given by the producer, but are to be regarded only as a means for choosing the right products in relation to the expected economically reasonable working life of the works.

2 Characteristics of product and methods of verification

2.1. Characteristics of product

The FM 753 anchor corresponds to the drawings and provisions given in Annexes 1 to 3. The characteristic material values, dimensions and tolerances of the anchor not indicated in Annexes 2 and 3 shall correspond to the respective values laid down in the technical documentation⁵ of this European Technical Approval. The characteristic anchor values for the design of anchorages are given in Annexes 4 to 5.

Each anchor is marked with the product name FM, the nominal diameter of the anchor, the maximum thickness of the fixture according to Annex 1 and the steel quality. A letter code corresponding to the total length of the bolt is punched on the head of the bolt.

⁵ The technical documentation of this European Technical Approval is deposited at the Centre Scientifique et Technique du Bâtiment and, as far as relevant for the tasks of the approved bodies involved in the attestation of conformity procedure, is handed over to the approved bodies.

The anchor shall only be packaged and supplied as a complete unit.

2.2. Methods of verification

The assessment of fitness of the anchor for the intended use in relation to the requirements for mechanical resistance and stability and safety in use in the sense of the Essential Requirements 1 and 4 has been made in accordance with the « Guideline for European Technical Approval of Metal Anchors for use in Concrete », Part 1 « Anchors in general » and Part 2 « Torque-controlled expansion anchors », on the basis of Option 7.

3 Evaluation of Conformity and CE marking

3.1. Attestation of conformity system

The system of attestation of conformity 2 (i) (referred to as system 1) according to Council Directive 89/106/EEC Annex III laid down by the European Commission provides:

a) tasks for the manufacturer:

1. factory production control,
2. further testing of samples taken at the factory by the manufacturer in accordance with a prescribed test plan.

b) tasks for the approved body:

3. initial type-testing of the product,
4. initial inspection of factory and of factory production control,
5. continuous surveillance, assessment and approval of factory production control.

3.2. Responsibilities

3.2.1. Tasks of the manufacturer, factory production control

The manufacturer has a factory production control system in the plant and exercises permanent internal control of production. All the elements, requirements and provisions adopted by the manufacturer are documented in a systematic manner in the form of written policies and procedures. This production control system ensures that the product is in conformity with the European Technical Approval.

The manufacturer shall only use raw materials supplied with the relevant inspection documents as laid down in the prescribed test plan⁶. The incoming raw materials shall be subject to controls and tests by the manufacturer before acceptance. Check of incoming materials such as nuts, washers, wire for bolts and metal band for expansion sleeves shall include control of the inspection documents presented by suppliers (comparison with nominal values) by verifying dimension and determining material properties, e.g. tensile strength, hardness, surface finish.

⁶ The prescribed test plan has been deposited at the Centre Scientifique et Technique du Bâtiment and is only made available to the approved bodies involved in the conformity attestation procedure.

The manufactured components of the anchor shall be subjected to the following tests:

- Dimensions of component parts:
 - bolt (diameters, lengths, thread, geometry of the cone, marking);
 - sleeve (length, thickness, catch sizes);
 - hexagonal nut (proper running, wrench size across flats);
 - washer (diameters, thickness).
- Material properties: bolt (yielding and ultimate tensile strengths), sleeve (ultimate tensile strength), hexagonal nut (proof load), washer (hardness).
- Visual control of correct assembly and of completeness of the anchor.

The frequency of controls and tests conducted during production and on the assembled anchor is laid down in the prescribed test plan taking account of the automated manufacturing process of the anchor.

The results of factory production control are recorded and evaluated. The records include at least the following information:

- designation of the product, basic material and components;
- type of control or testing;
- date of manufacture of the product and date of testing of the product or basic material and components;
- result of control and testing and, if appropriate, comparison with requirements;
- signature of person responsible for factory production control.

The records shall be presented to the inspection body during the continuous surveillance. On request, they shall be presented to the Centre Scientifique et Technique du Bâtiment.

Details of the extent, nature and frequency of testing and controls to be performed within the factory production control shall correspond to the prescribed test plan which is part of the technical documentation of this European Technical Approval.

3.2.2. Tasks of approved bodies

3.2.2.1. Initial type-testing of the product

For initial type-testing the results of the tests performed as part of the assessment for the European Technical Approval shall be used unless there are changes in the production line or plant. In such cases the necessary initial type-testing has to be agreed between the Centre Scientifique et Technique du Bâtiment and the approved bodies involved.

3.2.2.2. Initial inspection of factory and of factory production control

The approved body shall ascertain that, in accordance with the prescribed test plan, the factory and the factory production control are suitable to ensure continuous and orderly manufacturing of the anchor according to the specifications mentioned in 2.1. as well as to the Annexes to the European Technical Approval.

3.2.2.3. Continuous surveillance

The approved body shall visit the factory at least once a year for regular inspection. It has to be verified that the system of factory production control and the specified automated manufacturing process are maintained taking account of the prescribed test plan.

Continuous surveillance and assessment of factory production control have to be performed according to the prescribed test plan.

The results of product certification and continuous surveillance shall be made available on demand by the certification body or inspection body, respectively, to the Centre Scientifique et Technique du Bâtiment. In cases where the provisions of the European Technical Approval and the prescribed test plan are no longer fulfilled the conformity certificate shall be withdrawn.

3.3. CE-Marking

The CE marking shall be affixed on each packaging of anchors. The symbol « CE » shall be accompanied by the following information:

- identification number of the certification body;
- name or identifying mark of the producer and manufacturing plant;
- the last two digits of the year in which the CE-marking was affixed;
- number of the EC certificate of conformity;
- number of the European Technical Approval;
- use category (ETAG 001-1 Option 7);
- size.

4 Assumptions under which the fitness of the product for the intended use was favourably assessed

4.1. Manufacturing

The anchor is manufactured in accordance with the provisions of the European Technical Approval using the automated manufacturing process as identified during inspection of the plant by the Centre Scientifique et Technique du Bâtiment and the approved body and laid down in the technical documentation.

4.2. Installation

4.2.1. Design of anchorages

The fitness of the anchors for the intended use is given under the following conditions:

The anchorages are designed in accordance with the « Guideline for European Technical Approval of Metal Anchors for Use in Concrete », Annex C, Method A, for torque-controlled expansion anchors under the responsibility of an engineer experienced in anchorages and concrete work.

Verifiable calculation notes and drawings are prepared taking account of the loads to be anchored.

The position of the anchor is indicated on the design drawings (e.g. position of the anchor relative to reinforcement or to support, etc.).

4.2.2. Installation of anchors

The fitness for use of the anchor can only be assumed if the anchor is installed as follows:

- anchor installation carried out by appropriately qualified personnel and under the supervision of the person responsible for technical matters on the site;
- use of the anchor only as supplied by the manufacturer without exchanging the components of an anchor;
- anchor installation in accordance with the manufacturer's specifications and drawings prepared for that purpose and using the appropriate special tools;
- thickness of the fixture corresponding to the range of required thickness values for the type of anchor;
- checks before placing the anchor to ensure that the strength class of the concrete in which the anchor is to be placed is in the range given and is not lower than that of the concrete to which the characteristic loads apply;
- check of concrete being well compacted, e.g. without significant voids;
- clearing the hole of drilling dust;
- anchor installation ensuring the specified embedment depth;
- keeping of the edge distance and spacing to the specified values without minus tolerances;
- positioning of the drill holes without damaging the reinforcement;
- in case of aborted hole: new drilling at a minimum distance away of twice the depth of the aborted hole or smaller distance if the aborted drill hole is filled with high strength mortar and if under shear or oblique tension load it is not to the anchor in the direction of load application;
- application of the torque moment given in Annex 3 using a calibrated torque wrench.

4.2.3. Responsibility of the manufacturer

It is the manufacturer's responsibility to ensure that the information on the specific conditions according to 1 and 2 including Annexes referred to in 4.2.1. and 4.2.2. is given to those who are concerned. This information may be made by reproduction of the respective parts of the European Technical Approval. In addition all installation data shall be shown clearly on the package and/or on an enclosed instruction sheet, preferably using illustration(s).

The minimum data required are:

- drill bit diameter,
- thread diameter,
- maximum thickness of the fixture,
- minimum installation depth,
- minimum hole depth,
- required torque moment,
- information on the installation procedure, including cleaning of the hole, preferably by means of an illustration,
- reference to any special installation equipment needed,
- identification of the manufacturing batch.

All data shall be presented in a clear and explicit form.

**The original French version is
signed by**

**Le Directeur Technique
C. BALOCHE**

Assembled anchor :

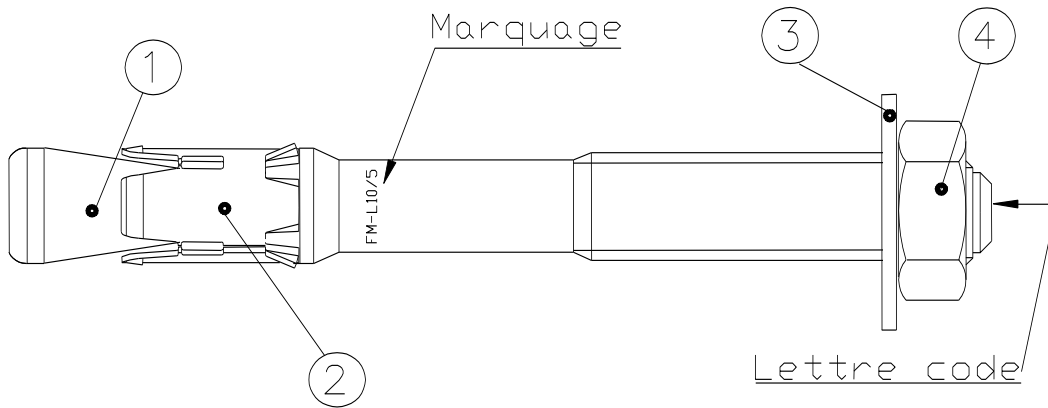

Schema of the anchor in use :

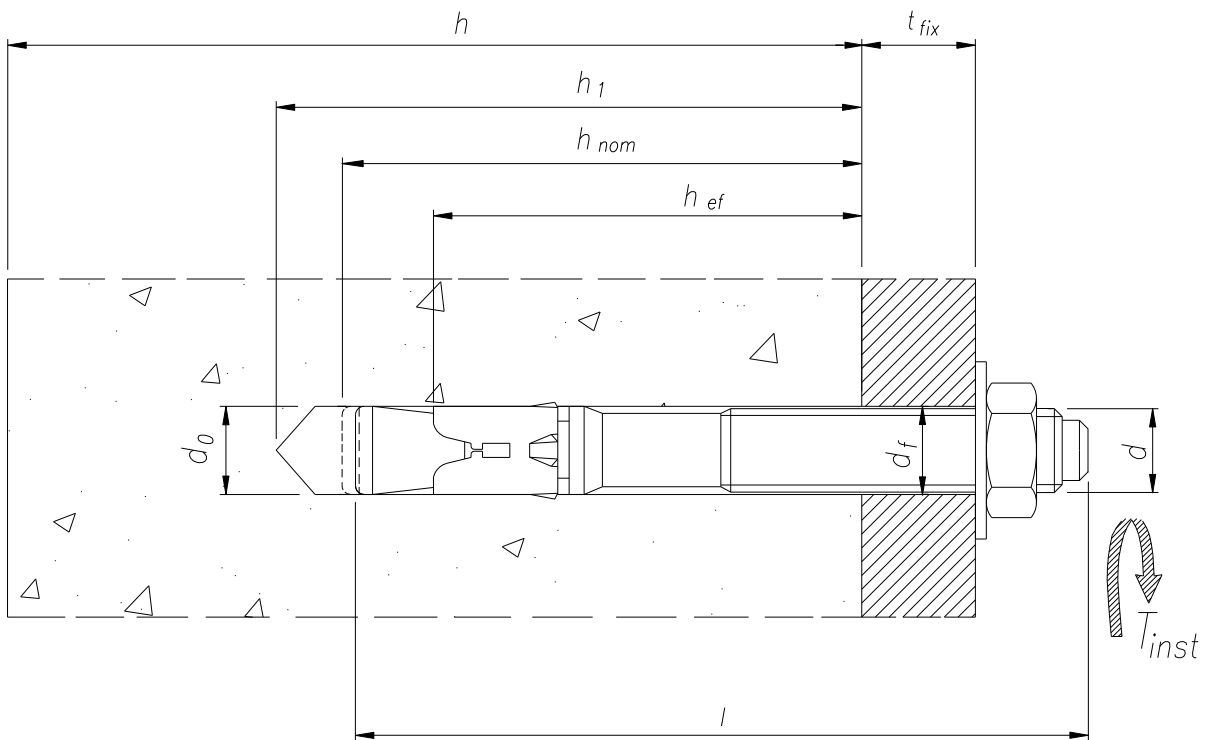

h_{ef} : effective anchorage depth
 h_{nom} : embedment depth
 h_1 : drilling hole depth
 t_{fix} : fixture thickness

FM 753 A4 torque-controlled expansion anchor

Product and intended use

Annex 1

of European
 Technical Approval
ETA- 01/0009

Anchor : bolt and sleeve

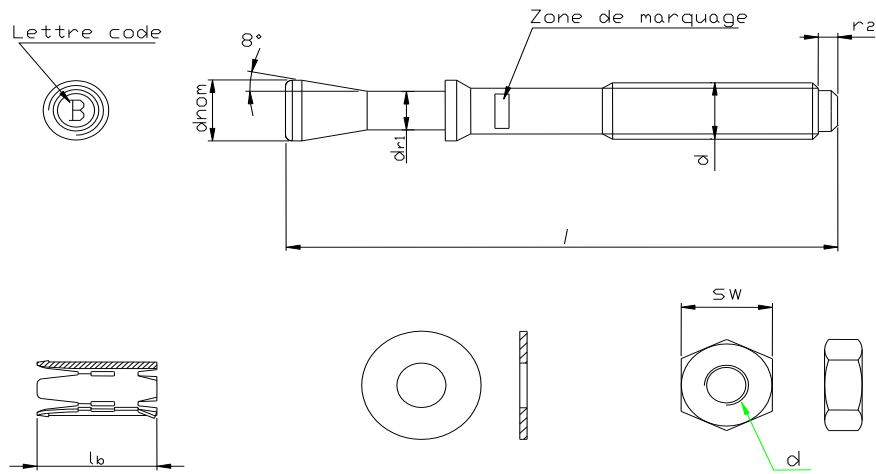

Table 1 : Matériaux

Part	Designation	Material
1	Bolt	Stainless steel AISI 316-L-Cu X3CrNiCuMo 17-11-3-2 (EN 10088/3) Stainless steel AISI 316-L X2CrNiMo 17-12-2 (EN 10088/3)
2	Sleeve	Stainless steel AISI 316-L X2CrNiMo 17-12-2 (EN 10088/2)
3	Washer	A4-140 Hv (DIN 125)
4	Hexagonal nut	A4-70 (EN 24032)

FM 753 A4 torque-controlled expansion anchor

Components and materials of the anchor

Annex 2

of European
 Technical Approval
ETA- 01/0009

Table 2: Dimensions

Anchor type	Marking	L (mm)	t _{fix} (mm)	d _r (mm)	d _{nom} (mm)	l _b (mm)	letter code
FM 753 A4 M8/65	FM 8/7 A4	65	7	5,8	8,0	11,5	B
FM 753 A4 M8/75	FM 8/15 A4	75	15				C
FM 753 A4 M8/90	FM 8/30 A4	90	30				D
FM 753 A4 M8/115	FM 8/55 A4	115	55				E
FM 753 A4 M8/135	FM 8/75 A4	135	75				F
FM 753 A4 M8/165	FM 8/105 A4	165	105				G
FM 753 A4 M10/75	FM 10/5 A4	78	5	7,4	10,0	14,0	B
FM 753 A4 M10/90	FM 10/20 A4	90	20				C
FM 753 A4 M10/120	FM 10/50 A4	120	50				D
FM 753 A4 M10/145	FM 10/75 A4	145	75				E
FM 753 A4 M10/170	FM 10/100 A4	173	100				F
FM 753 A4 M12/100	FM 12/10 A4	100	10	8,8	12,0	17	B
FM 753 A4 M12/110	FM 12/20 A4	110	20				C
FM 753 A4 M12/135	FM 12/45 A4	135	45				D
FM 753 A4 M12/160	FM 12/70 A4	160	70				E
FM 753 A4 M12/185	FM 12/100 A4	188	100				F
FM 753 A4 M16/125	FM 16/10 A4	125	10	12,6	16,0	23	A
FM 753 A4 M16/145	FM 16/30 A4	145	30				B
FM 753 A4 M16/175	FM 16/60 A4	175	60				C
FM 753 A4 M16/215	FM 16/100 A4	215	100				D

Table 3: Installation data

Anchor type	d _{cut} (mm)	d _r (mm)	T _{inst} (Nm)	h _{min} (mm)	h ₁ (mm)	h _{nom} (mm)	h _{ef} (mm)	S _{min} (mm)	C _{min} (mm)
FM 8/7 A4 FM 8/15 A4 FM 8/30 A4 FM 8/55 A4 FM 8/75 A4 FM 8/105 A4	8	9	15	100	60	48	40	60	60
FM 10/5 A4 FM 10/20 A4 FM 10/50 A4 FM 10/75 A4 FM 10/100 A4	10	12	25	100	70	59	50	75	75
FM 12/10 A4 FM 12/20 A4 FM 12/45 A4 FM 12/70 A4 FM 12/100 A4	12	14	50	120	85	71	60	90	90
FM 16/10 A4 FM 16/30 A4 FM 16/60 A4 FM 16/100 A4	16	18	100	170	115	96	85	130	130

FM 753 A4 torque-controlled expansion anchor

dimensions of anchors and installation data

Annex 3

of European
 Technical Approval
ETA- 01/0009

Table 4: Characteristic values of resistance to tension loads of design method A

			M8	M10	M12	M16
Steel failure						
Characteristic resistance (reduced part)	$N_{Rk,s}$	(kN)	17,2	28,0	39,5	81,0
Partial safety factor	γ_{Ms}	-	1,59	1,59	1,59	1,59
Pull-out failure						
Characteristic resistance in non-cracked concrete C20/25	$N_{Rk,p}$	(kN)	7,5	12	-*	35
Partial safety factor	γ_2	-	1,0	1,0	1,0	1,0
	γ_{Mp}	-	1,50	1,50	1,50	1,50
Concrete cone failure and splitting failure						
Effective anchorage depth	h_{ef}	(mm)	40	50	60	85
Spacing	$s_{cr,N}$	(mm)	120	150	180	255
	$s_{cr,sp}$	(mm)	240	300	360	510
Edge distance	$c_{cr,N}$	(mm)	60	75	90	130
	$c_{cr,sp}$	(mm)	120	150	180	255

* pull-out failure is not a decisive failure mode for size M12.

			M8	M10	M12	M16
Increasing factor for pull-out and concrete cone failure						
Increasing factor	ψ_c (C30)	-	1,17		1,22	
	ψ_c (C40)	-	1,32		1,41	
	ψ_c (C50)	-	1,42		1,55	

Table 5 : Displacements under tension loads

			M8	M10	M12	M16
Tension load (kN) in non-cracked concrete C20/25 to C50/60			3,6	5,7	11,1	16,7
Displacement	δ_{N0}	(mm)	0,1	0,2	0,3	1,2
	$\delta_{N\infty}$	(mm)	1,6	1,6	1,6	1,6

FM 753 A4 torque-controlled expansion anchor

Design method A : characteristic values of resistance to tension loads and displacements

Annex 4

of European
 Technical Approval
ETA- 01/0009

Table 6: Characteristics values of resistance to shear loads of design method A.

			M8	M10	M12	M16
Steel failure without lever arm						
Characteristic resistance	$V_{Rk,s}$	(kN)	11,9	18,9	27,4	51,0
Partial safety factor	γ_{Ms}	-	1,33	1,33	1,33	1,33
Steel failure with lever arm						
Characteristic resistance	$M_{Rk,s}$	(Nm)	24	49	85	216
Partial safety factor	γ_{Ms}	-	1,33	1,33	1,33	1,33
Concrete pryout failure						
Factor in equation (5.6) of ETAG Annex C, § 5.2.3.3	k	-	1	1	2	2
Partial safety factor	γ_2	-	1	1	1	1
	γ_{Mpr}	-	1,50	1,50	1,50	1,50
Concrete edge failure						
Effective length of anchor Under shear loading	l_f	(mm)	40	36	43	62
Outside diameter of anchor	d_{nom}	(mm)	8	10	12	16
Partial safety factor	γ_2	-	1	1	1	1
	γ_{Mc}	-	1,50	1,50	1,50	1,50

Tableau 7: Displacements under shear loads

		M8	M10	M12	M16
Shear load (kN) in non-cracked concrete C20/25 to C50/60		6,4	10,1	14,8	27,5
Displacement*	δ_{v0} (mm)	0,8 (+0,7)	0,9 (+1,2)	1,0 (+1,2)	1,2 (+1,2)
	$\delta_{v\infty}$ (mm)	1,3 (+0,7)	1,4 (+1,2)	1,5 (+1,2)	1,8 (+1,2)

* Displacement : the table shows the deformation to be expected from the anchor itself, whilst the bracket value indicates the movement between the anchor body and the hole drilled in the concrete member or the hole in the fixture.

FM 753 A4 torque-controlled expansion anchor

Design method A : characteristic values of resistance to shear loads and displacements

Annex 5

of European
 Technical Approval
ETA- 01/0009